

*...a trip down the memory lane ...*

**Industry**  
**Textile - Ring Frame**

# **POWER TRANSMISSION REPORT**

**GIVING DRIVE SOLUTION FOR MAIN  
MOTOR DRIVE FLAT BELT FOR RC II  
RING FRAME, MMC- MARZOLI,**

**ONE OF THE LARGEST TEXTILES OEM IN 80'S.**

**Power Transmission, Conveyor & Automation  
with Belts**

## Issue

In early 1981, we were urgently called to resolve severe issues in the Main drive Belt at the newly introduced MMC Marzoli Ring Frame RC 2 Ring Frame. These were challenging moments as thousands of new high-speed machines were planned to be sold from their Mysore plant.

The already fitted imported Chiorino Z2 Belts were not taking load and will often snap out on start.

## Solution

Problems were resolved by Belting within a few hours. All it needed was some minor changes and in work practices / preventive care.

Interesting part of the story is that we had just started that we were just in contact with Chiorino and not authorized to represent them. On repeated request, we visited Mysore to meet MMC Marzoli design head Mr. T.K. Sen.

Thanks to our vast experience in Flat Transmission belts — in just a few hours of brainstorming, a few corrections & a confident plan of action was concluded.

Problems that looked overly complex had been resolved with some quite simple corrective solutions. MR T K Sen acclaimed us with overwhelming remarks after the job was done.

MMC Marzoli

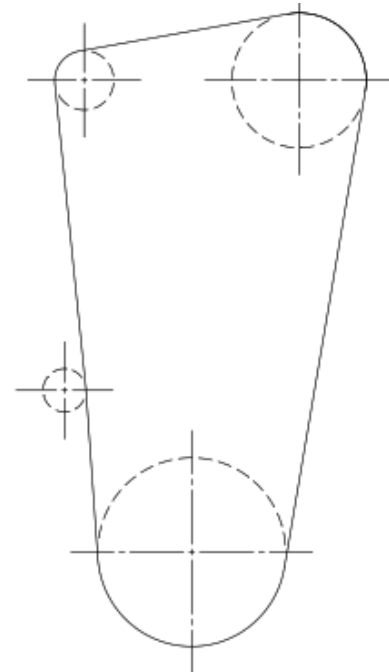

An Indicative Diagram

Problems that looked overly complex had been resolved with some quite simple corrective solutions. MR T K Sen acclaimed us with overwhelming remarks after the job was done.

We won some friends in MMC & fortunate to have a very long association with them with many more stories of new designs and troubleshooting.

We signed a contract with Chiorino for future flat belt co-operation.

